



Air Conditioners

Heating & Cooling

Rooftop Unit

R-410A

- » High efficiency
- » Wide operation range
- » Compact unit
- » Plug and play installation
- » Field convertible return and supply air



www.daikin.eu



UATYQ-BY1



Rooftops R-410A – 25-70 kW: Features

- › Flexible air supply: Since all the units utilize a belt/ pulley driven supply air fan, the units are able to meet a wide range of supply air volumes and external static pressures. Furthermore, the supply air fan motors, pulleys and belts (field supplied) can be easily changed on site to meet exact air flow and ESP requirement if required.
- › Refrigerant is pre-factory charged to ensure **clean and efficient operation**
- › **Electric heater connection**
- › Coil with **anti-corrosion treatment** (gold fin)
- › **Electronic expansion valve** for better control of the refrigerant flow
- › **Cut-off switch** for emergency power cut-off

Control :

- › New **control panel** offered as standard
- › **Extended control length** up to 100m
- › Connectable to **Daikin control systems** (via option)



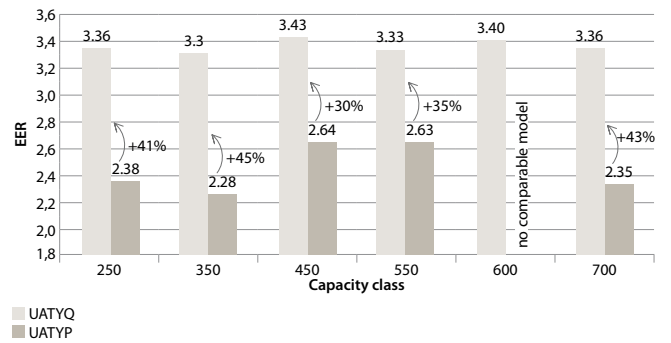

> **High efficiency**

An EER up to 3,43 thanks to the combination of high efficient and reliable scroll compressors and R-410A refrigerant.

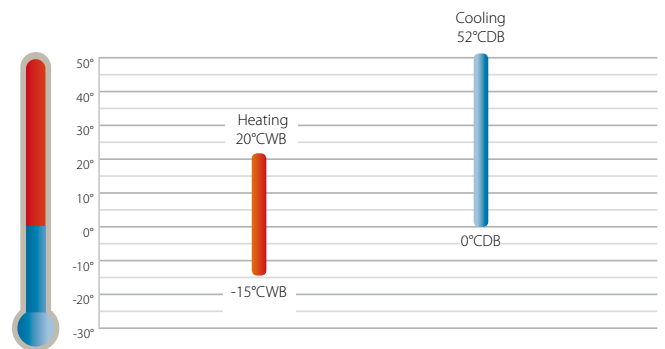

> **Wide operation range**

The UATYQ-BY1 series operate from 52°CDB down to 0°CDB in cooling and from 20°CWB down to -15°CWB in heating.



> **Compact unit**

The flat top design of the unit allows for maximum utilization of warehouse and container space

> **Plug and play installation**

The single unit configuration requires no additional piping work as both the indoor and outdoor sides are pre-connected. Once the ductwork is installed, the only thing left to do is connect the unit



> **Field convertible return and supply air:**

Fan can be mounted in two directions

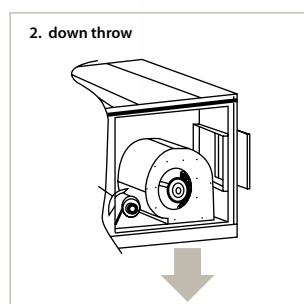
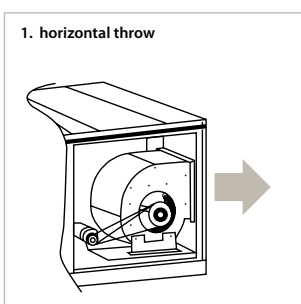



Heating & Cooling

OUTDOOR UNITS				UATYQ250BY1	UATYQ350BY1	UATYQ450BY1	UATYQ550BY1	UATYQ600BY1	UATYQ700BY1
Capacity	cooling	nominal	kW	27.34	35.58	44.72	55.69	66.82	72.60
	heating	nominal	kW	24.91	34.79	41.79	53.93	61.69	69.61
Power input	cooling	nominal	kW	8.14	10.78	13.04	16.74	19.65	21.61
	heating	nominal	kW	7.33	10.84	12.86	15.54	18.58	21.42
EER	cooling			3.36	3.30	3.43	3.33	3.40	3.36
COP	heating			3.40	3.21	3.25	3.47	3.32	3.25
Air Flow Rate evaporator	cooling		l/s	1,560	2,030	2,670	3,160	3,445	3,917
Evaporator	sound power level	100 ESP	dB(A)	68	72	75	82	84	87
External Static Pressure			Pa		147		206		206
Condensation Drain Size	diameter	od	mm				25.4		
Casing	colour								
	material						Light grey Electro galvanised mild steel		
Dimensions	unit	HxWxD	mm	1,150x1,638x2,063	1,028x2,209x2,113	1,130x2,209x2,113	1,048x2,200 x2,670		1,302x2,209x2,670
Weight	unit		kg	490	660	610	780	830	970
Air Flow Rate condenser	cooling		l/s	3,884	5,664	5,710	6,090	9,534	10,006
Operation Range	cooling	min-max	°CDB						
	heating	min-max	°CWB				0°C - 52°C -15°C - 20°C		
Condenser	sound power level	nominal	dB(A)	82	83		87		90
Refrigerant	type						R-410A		
Power Supply							3~/380-415V/50Hz		



Remote control
as standard



Outdoor unit
UATYQ-BY1



Daikin's unique position as a manufacturer of air conditioning equipment, compressors and refrigerants has led to its close involvement in environmental issues. For several years Daikin has had the intention to become a leader in the provision of products that have limited impact on the environment. This challenge demands the eco design and development of a wide range of products and an energy management system, resulting in energy conservation and a reduction of waste.



The present leaflet is drawn up by way of information only and does not constitute an offer binding upon Daikin Europe N.V. Daikin Europe N.V. has compiled the content of this leaflet to the best of its knowledge. No express or implied warranty is given for the completeness, accuracy, reliability or fitness for particular purpose of its content and the products and services presented therein. Specifications are subject to change without prior notice. Daikin Europe N.V. explicitly rejects any liability for any direct or indirect damage, in the broadest sense, arising from or related to the use and/or interpretation of this leaflet. All content is copyrighted by Daikin Europe N.V.

ECPEN10-120 - 350 - 05/10 - Copyright Daikin
The present publication supersedes ECPEN10-120_P
Printed on non-chlorinated paper. Prepared by La Movida, Belgium.
Resp. Ed.: Daikin Europe N.V., Zandvoordestraat 300, B-8400 Oostende



Daikin products are distributed by: